

# FT722-FF (FLAT FRONT)



## ACOUSTIC RESONANCE WIND SENSOR

### DESIGNED FOR TURBINE CONTROL

The FT722 Flat Front wind sensor is designed for quick and easy installation against a metal bar. The bar allows the sensor to be aligned to the central axis of the turbine without error.

Ideal for retrofit, the sensor provides a single, compact solution to replacing an existing mechanical wind vane and anemometer wind measurement system. With no moving parts to wear out or degrade, turbine downtime is reduced, power output is increased and yaw control is more efficient. With updated software and improved accuracy, it is also a fit and function replacement for the FT702LT-FF sensor.

The FT722-FF has sufficient heating capacity to keep itself ice-free and to heat the mounting bar. This prevents ice from building up and blocking air flow through the measurement cavity. It has passed over 28 environmental tests to demonstrate its durability.

### DIMENSIONS

A. Sensor height.....	161mm
B. Sensor width max.....	56mm
C. Top of mounting flat to cavity centre.....	66.3mm
D. Mounting flat height.....	25mm
E. Bottom of mounting flat to hole centre.....	17mm
F. Centre of mounting flat to hole centre.....	5.1mm

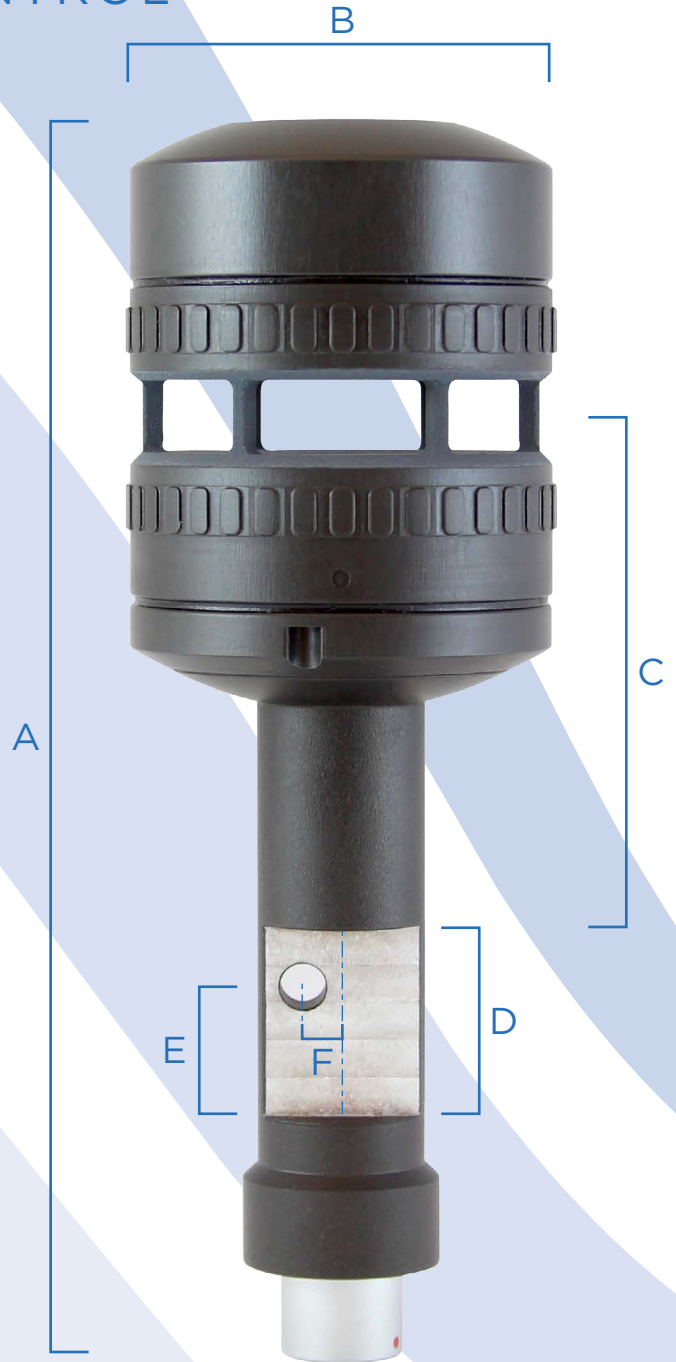

### SPECIFICATIONS AT A GLANCE

WIND SPEED

0-50 m/s

WEIGHT

320 g

AVAILABILITY

> 99.9 %

# FT722-FF (FLAT FRONT)

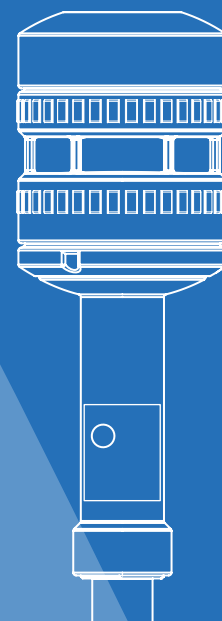

## WIND SPEED

Range.....	0-50m/s
Resolution.....	0.1m/s
Accuracy.....	±0.3m/s (0-16m/s) ±2% (16-40m/s) ±4% (40-50m/s)

## WIND DIRECTION

Range.....	0 to 360°
Resolution.....	1°
Accuracy (within ±10° datum).....	2° RMS
Accuracy (outside ±10° datum).....	4° RMS

## SENSOR PERFORMANCE

Measurement principle.....	Acoustic Resonance (automatically compensates for variations in temperature, pressure & humidity).
Units of measure.....	metres per second, kilometres per hour or knots
Altitude.....	0-4000m operating range
Temperature range.....	-40° to +85°C (operating and storage)
Humidity.....	0-100%
Ingress protection.....	IP66 and IP67
Heater settings.....	0° to 55°C. The heater set point can be configured

## POWER REQUIREMENTS

Supply voltage.....	12V to 30V DC (24V DC nominal)
Supply current (heater off).....	31mA typical
Supply current (heater on).....	Limited to 4A (default), 6A (max) – configurable in software in 0.1A increments. Heater power consumption will depend on the energy required to keep the sensor's temperature at the user determined set point. The heater and sensor power consumption is limited by default to 99W.

## PHYSICAL

I/O connector.....	5-way (RS485 option), 8-way (4-20mA option) multipole connector
Sensor weight.....	320g

## DIGITAL SENSOR

Interface.....	RS485 (half-duplex), galvanically isolated from power supply lines and case
Format.....	ASCII data, polled or continuous output modes, Polar and NMEA 0183
Data update rate.....	Maximum 10 measurements per second
Error handling.....	When the sensor detects an invalid reading a character is set in the wind velocity output message. This error flag character is 1

## ANALOGUE SENSOR

Interface.....	4-20mA, galvanically isolated from power supply lines and case.
Format.....	One 4-20mA current loop for wind speed (different scaling factors are available). One 4-20mA current loop for wind direction (datum value configurable as 4mA or 12mA). Both analogue channels are updated ten times per second.
4-20mA configuration port.....	This port is for the user to change the internal settings of analogue sensors and to perform diagnostic testing. This interface is not intended for permanent connection to a data logger or other device.
Error handling.....	When the sensor detects an invalid reading then both speed and direction current loops will drop to a default value of 1.4mA (configurable up to 3.9mA).

## EMC AND ENVIRONMENTAL TESTS

The FT7 Series have passed over 28 different environmental test certificates including Corrosion, Icing, De-Icing, Shock, Hail, Drop, ESD, power interruption and EMC. Further test details and full test reports available on request or via our website.

FT Technologies Ltd  
Sunbury House, Brooklands Close  
Sunbury on Thames, TW16 7DX, UK  
Tel: +44 (0)20 8943 0801 | info@fttechnologies.com

The FT and Acu-Res logos and the Acu-Res® name are registered trade marks of FT Technologies Ltd.



A4153-3-EN  
Information furnished by FT Technologies Ltd is believed to be accurate and reliable. However, no responsibility is assumed by FT Technologies Ltd for its use; nor for any infringements of patents or other rights of third parties which may result from its use. No licence is granted by implication or otherwise under any rights of FT Technologies Ltd.